

# The Path to Convergence

Jackie Bell  
University of Calgary

September 15, 2009



# Calgary, Alberta, Canada



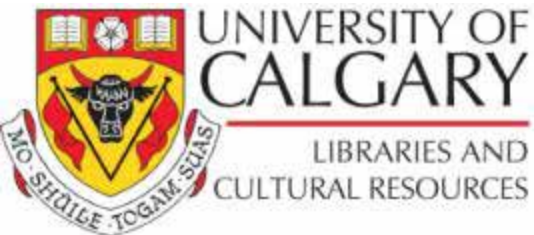

## Libraries and Cultural Resources

- Taylor Family Digital Library
- Four Campus Branches
- Archives & Special Collections
- The Nickle Arts Museum
- University of Calgary Press
- Doha, Qatar
- High Density Library
- Health Information Network
- The Military Museums
- Downtown Campus Library

# Taylor Family Digital Library Project

265,000 sq.ft.



# Taylor Family Quadrangle Project

Newly landscaped  
“green space”  
in the heart of campus

As the principal approach to  
the new Library



# High Density Storage Facility Project

Books, Journals, Archives & Art





# LAM

---

Central **L**ibrary      University **A**rchives

The Nickle Arts **M**useum      University Press

---





# LAMP

Libraries, Archives, Museum & Press



# Centre for Student Success Partnership with the Office of Vice Provost for Students

Full-Scale Collaboration

Seamless Integration of Learning  
Support Services

Student Advising

Aid for Students with Disabilities

Information Literacy

Digital Literacy Classroom  
Instruction

Technology Training



# Technology

## Mechanical, Electrical and Data Systems

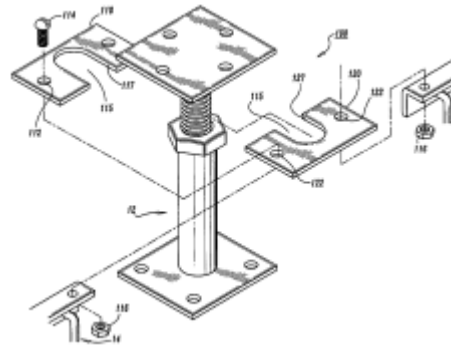
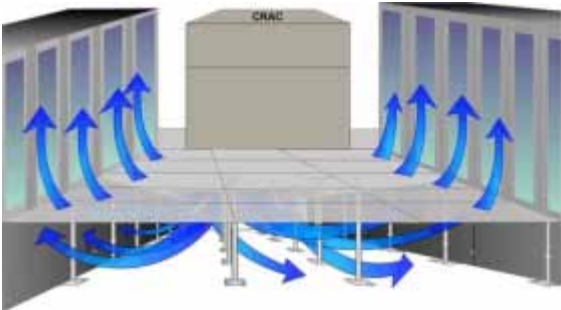



## Enhanced Capabilities



# Knowledge Creation Technologies



But it's not about  
the facilities.

It's about us



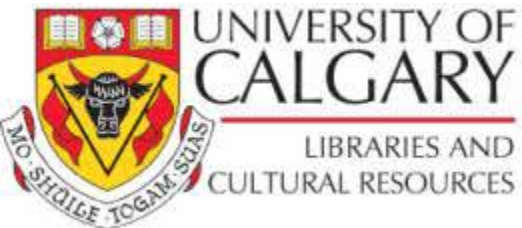

## **Convergence: The Vision**

Provide outstanding support for Scholarship, Learning and the Creation of Knowledge.

We are not limited by traditional roles.

We will fulfill this vision through a convergence of our Libraries, Museum, Archives, Special Collections and University Press.

*We Should Imagine Greatness*



“True collaboration...devises a new vision for a new way of doing things.

It inevitably and fundamentally involves change.

Collaboration is transformational, and the elements, institutions and individuals involved in collaboration must change.”

Ken Soehner, Chief Librarian,  
Metropolitan Museum of Art



**We Have to Change**



# Strengthen our Unique Collections



Carpas  
Great Britain - Lichfield, West Yorkshire



Cast bronze quadrans of the Roman Republic, about 240 BC.  
Collection of The Nickle Arts Museum



# Commit to Being Digital



# Digital Access to Alberta's Heritage

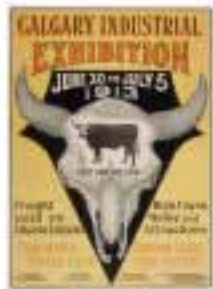

# Digital Objects of Scholarly Interest





# New Media Art

Exhibit art throughout the building

Across Campus, the Community and into local Classrooms





# Taylor Family Digital Library Is Designed as an Ideal Reflection Of the Converged Environment





How do we realize change?



# The Convergence of Knowledge and Culture Speakers Series



**Ingrid Parent**

**Then:** Assistant Deputy Minister for the  
Documentary Heritage Collection  
Sector at Library and Archives Canada

**Now:** University Librarian  
University of British Columbia



**Seamus Ross**

Dean  
Faculty of Information  
University of Toronto



# Planning for Convergence

## Implementation Planning Committees

---

Collections   Learning   Media/Technology   Outreach   Research   Staffing

---

### Organizational Review and Strategic Re-Alignment





---

Consultation with staff, students, faculty,  
community, partners, university  
administration





---

# Some Major Themes

---

Electronic access

Digitization

Expert assistance

Research platform





---

# Epiphany

---

The first transition to a different perspective occurred as we read the literature. Discussions and exploration during meetings provided a further impetus....

- Peggy White, Director, Implementation Planning Team, 2009





# Example 1 of our New Converged Vision

## Centre for Arts and Culture

A Concept in Development

Archives, Rare Books, Special Collections, Art & Artifacts

Where Curators & Archivists actively collaborate



## Art & Archives

# Art, Archives and Artifacts as Teaching Tools

Class Instruction

Workshops

Student Assistance

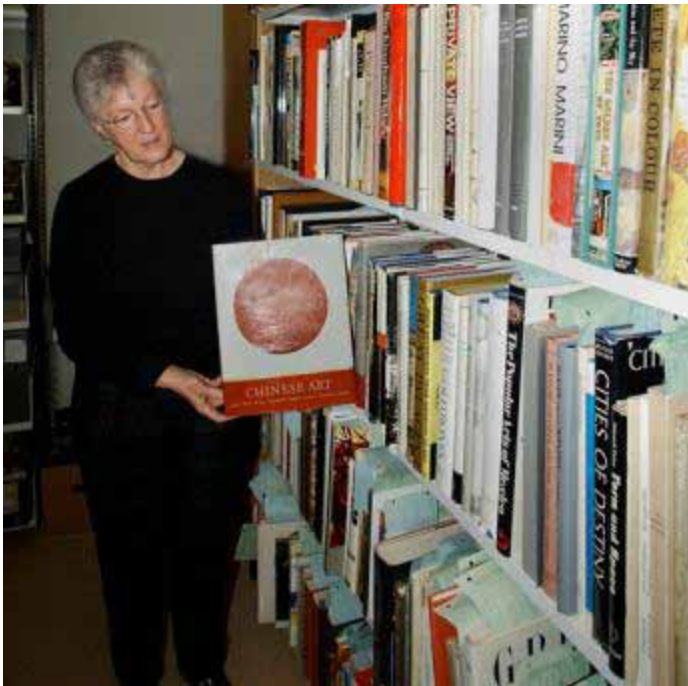



# Community Role Centre for Arts and Culture

Centre for Arts and Culture will exercise an expanding Community Role

Do away with Museum Admission Fees

Collect and Preserve the Documentary Heritage of Our Region

Expand the Museum's Local Artist Collections



## Example 2 of our New Converged Vision Metadata Services

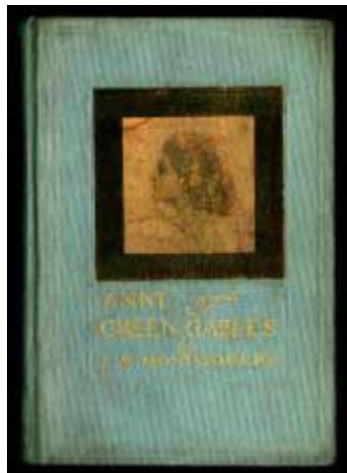

# The Collection of the Future

## Redefining the Collection



# More than Book and Journal Counts



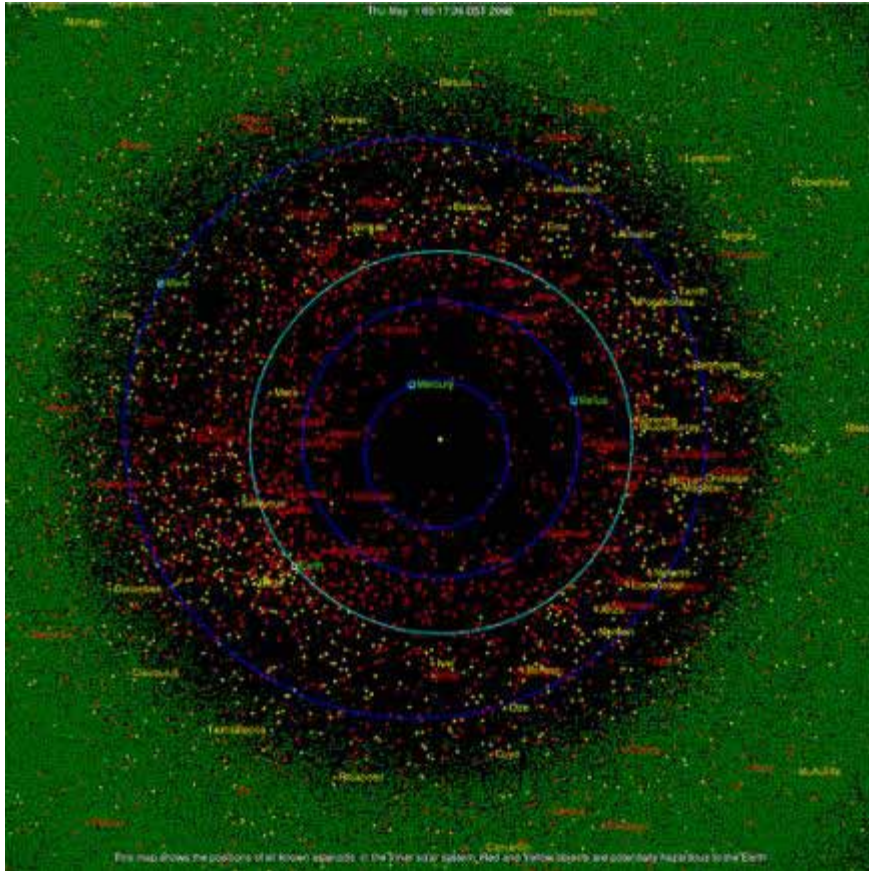

## Real-Time Digital Primary Resources

Visualization of Real-Time Asteroid Data

# Building and Use Data Will Become Collections in Themselves

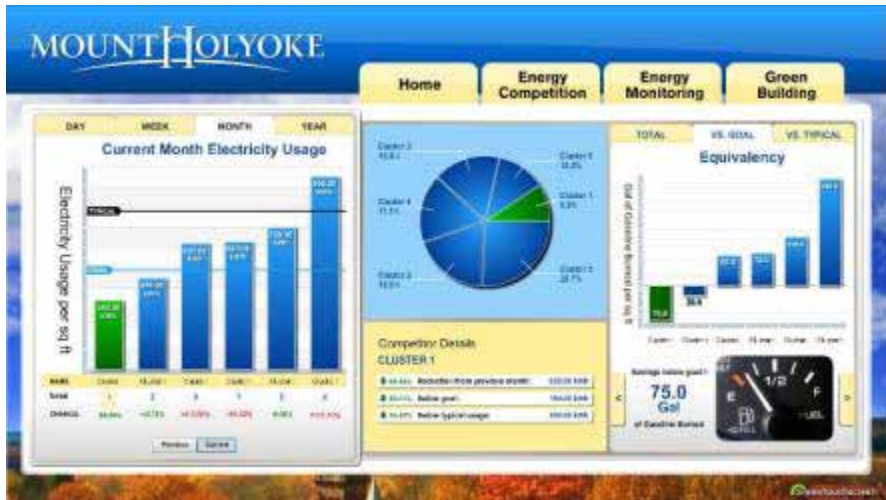

# Commit to Being Digital

## Making Collections Work for Users

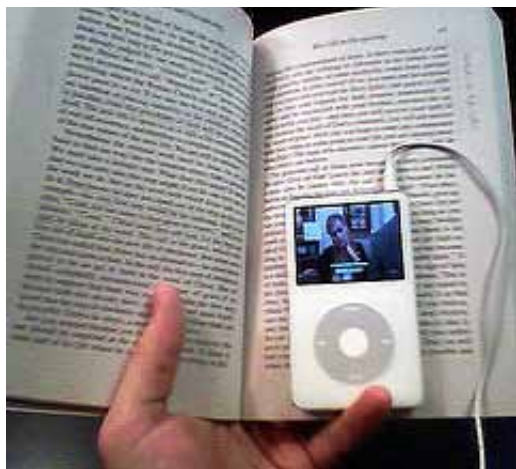



# The Collection of the Future

“These are the shelves and spine labels of the digital collection, the irreducible accompaniments that make information accessible and useful.”

Helen Clarke, Head of Collections Services,  
University of Calgary



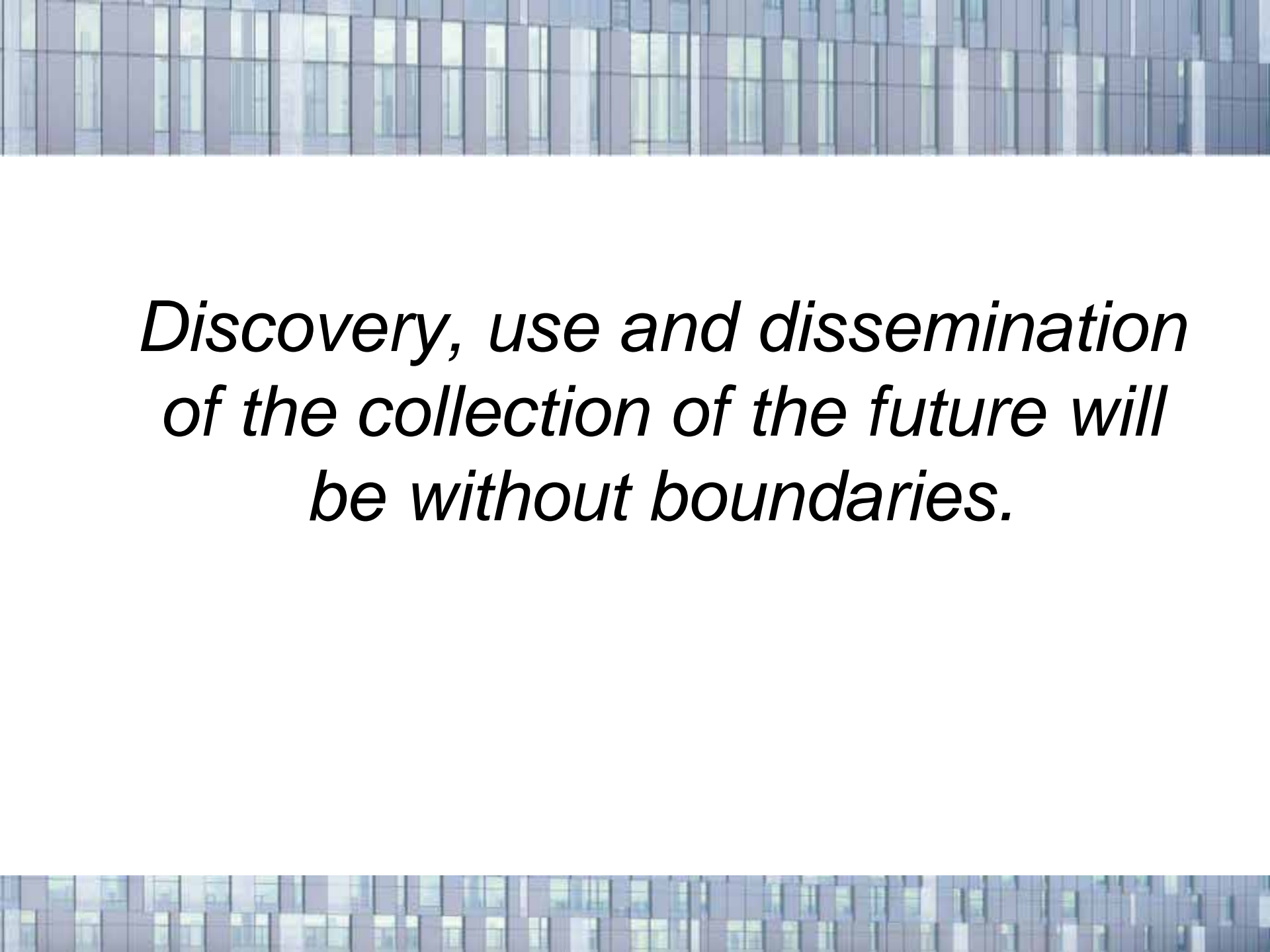

*Discovery, use and dissemination  
of the collection of the future will  
be without boundaries.*



*“The task of the LAMP will be to articulate a new vision of convergence revealing the wealth and diversity of human experience.”*

Tom Hickerson, Vice Provost Libraries and Cultural Resources, University of Calgary





